

Item	Description	Q'ty	Type	Material	Part No.	Code No.	
1	Front Case	1	"V" (FKM)	GFRPP	SMX0093	1210044300	
		1	"E" (EPDM)	GFRPP	SMX0149	1231217800	
2	Rear Case (+Liner Ring) Unit	1		GFRPP+Ceramic	SMX0094	1210044400	
3	Rear Casing	1		GFRPP	SMX0095	1220310200	
*4	Volute Spacer (for "V" only)	1	542•543•545-V	GFRPP	SMX0096	1240859200	
6	Plate	1		GFRPP	SMX0097	1220310100	
7	Cap	1		GFRPP	SMX0008	1240833200	
8	Drain Cap	1		GFRPP	SMX0009	1240833300	
9	Impeller (with Mouth Ring) Unit	1	542•543•545-V	GFRPP+PTFE	SMX0099	1240858700	
		1	543•545-T	GFRPP+PTFE	SMX0100	1240858600	
*10	Drive Magnet Unit <*See Note below>	<J2>	542 [1,5kW]	FCD450+R-E Mag.	MX0310	1230987200	
		<J3>	543 [2,2kW]	FCD450+R-E Mag.	MX0323	1230987300	
		<XJ5>	545 [4,0kW]	FCD450+R-E Mag.	MXM0092	1220300200	
11.1	Magnet Capsule+ Bearing Unit	542	1	CAV•CAE	PP+Carbon+R-E M.	MX0178	1230987810
			1	RAV•RAE	PP+PTFE+R-E M.	MX0179	1230987820
			1	KAV•KAE	PP+SiC+R-E M.	SMX0103	1230987830
		543•545	1	CAV•CAE	PP+Carbon+R-E M.	MX0186	1230987910
			1	RAV•RAE	PP+PTFE+R-E M.	MX0187	1230987920
1	KAV•KAE	PP+SiC+R-E M.	SMX0132	1230987930			
11.2	Lock Pin	2		GFRPPS	MX0308	1240736600	
13.1	Cap Bolt	6	M10x50	SUS304 equivalent	SMX0119	0150300254	
13.2	Cap Bolt	3	M10x16	SUS304 equivalent	SMX0120	0150300040	
13.3	Cap Bolt with W.	542•543	4	M8x20	Steel	MX0219	0150900033
	Cap Bolt	545	4	M10x16	SUS304 equivalent	SMX0120	0150300040
13.4	Cap Bolt	2	M10x90	SUS304 equivalent	SMX0121	0150300615	
14.1	Hex. Head Bolt	542•543	4	M10x30	SUS304 equivalent	MDM0040	0150100182
		545	4	M12x40	SUS304 equivalent	MDM0555	0150100208
14.2	Hex. Head Bolt	542•543	4	M10x25	SUS304 equivalent	MDM0041	0150100181
		545	4	M10x30	SUS304 equivalent	MDM0040	0150100182
15	Stud Bolt	5	M10x168	SUS304	SMX0122	1240859400	
16.1	Nut	13	M10	SUS304 equivalent	SMX0123	0153100031	
16.2	Cover Cap	13		PE	SMX0124	0159000003	

\*Note: "Drive Magnet Unit" (Item No. 10) is furnished with 2 x Setscrew (M8x10).

⚠ Subject to change without prior notice! ⚠ Actual pump may differ from the exploded view!

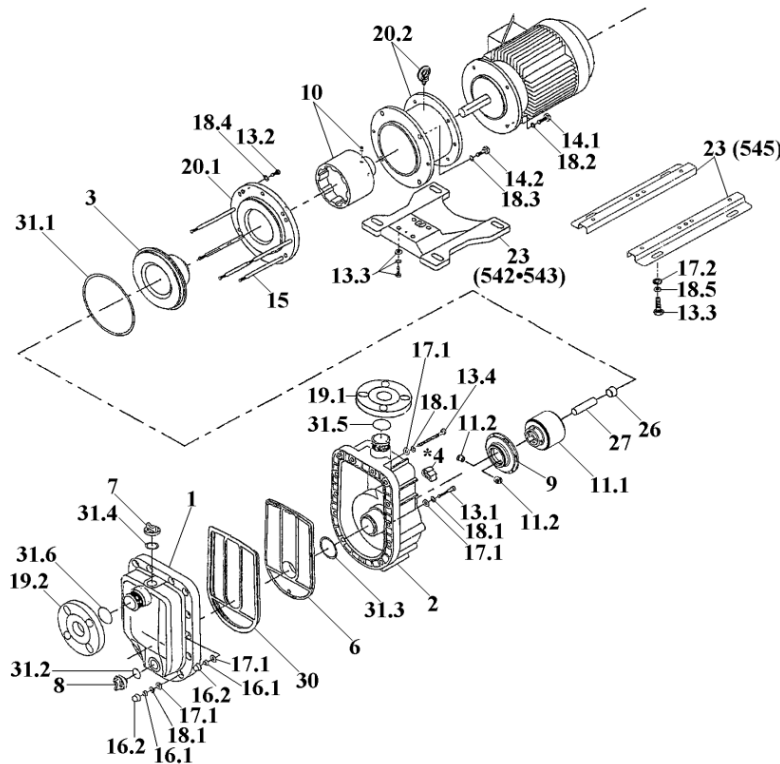

Item	Description	Q'ty	Type	Material	Part No.	Code No.
17.1	Plate Washer	21	M10	SUS304 equivalent	SMX0125	0153500028
17.2	Plate Washer	545 4	M10	SUS304 equivalent	SMX0139	0153500073
18.1	Spring Washer	13	M10	SUS304 equivalent	MDM0030	0154100022
18.2	Spring Washer	542•543 4	M10	SUS304 equivalent	MDM0030	0154100022
		545 4	M12	SUS304 equivalent	MDM0029	0154100024
18.3	Spring Washer	4	M10	SUS304 equivalent	MDM0030	0154100022
18.4	Spring Washer	3	M10	SUS304 equivalent	MDM0030	0154100022
18.5	Spring Washer	545 4	M10	SUS304 equivalent	MDM0030	0154100022
19.1	Discharge Flange	1	40mm	GFRPP	MX0299	1230253300
19.2	Suction Flange	1	50mm	GFRPP	MX0298	1230253400
20.1	Rear Casing Support	1		FCD450	SMX0126	1220310500
20.2	Adapter <*See Note below>	542•543 1	1,5•2,2kW	FCD450	SMX0127	1210044500
		545 1	4,0kW	FCD450	SMX0140	1210044600
23	Base	542•543 1		GFRPP	SMX0073	1220303100
		545 2		Steel	SMX0143	1231204000
26	Rear Thrust	1	CA•RA	Alumina Ceramic	SMX0107	1240858400
		1	KA	SiC	SMX0108	1240858500
27	Spindle	1	CA•RA	Alumina Ceramic	SMX0109	1240864000
		1	KA	SiC	SMX0110	1240864100
30	Gasket	V 1		FKM-A	SMX0111	1220310600
		E 1		EPDM	SMX0112	1220310700
31.1	O-Ring <R.Casing>	V 1	G-180	FKM-A	SMX0113	0325300491
		E 1		EPDM	SMX0114	0325300492
31.2	O-Ring <Drain>	V 1	G-25	FKM-A	MX0117	0325300203
		E 1		EPDM	MX0205	0325300179
31.3	O-Ring <R. Case>	V 1	G-55	FKM-A	SMX0115	0325300326
		E 1		EPDM	SMX0116	0325300493
31.4	O-Ring <Cap>	V 1	G-30	FKM-A	SMX0029	0325300053
		E 1		EPDM	SMX0030	0325300087
31.5	O-Ring <Outlet>	V 1	AS568-129	FKM-A	MX0130	0325500010
		E 1		EPDM	MX0233	0325500014
31.6	O-Ring <Inlet>	V 1	AS568-136	FKM-A	MX0181	0325500011
		E 1		EPDM	MX0300	0325500015

\*Note: "Adapter" (Item No. 20.2) is furnished with 1 x Eyebolt (M10).

△ Subject to change without prior notice! △ Actual pump may differ from the exploded view!