

MXM 542•543•545

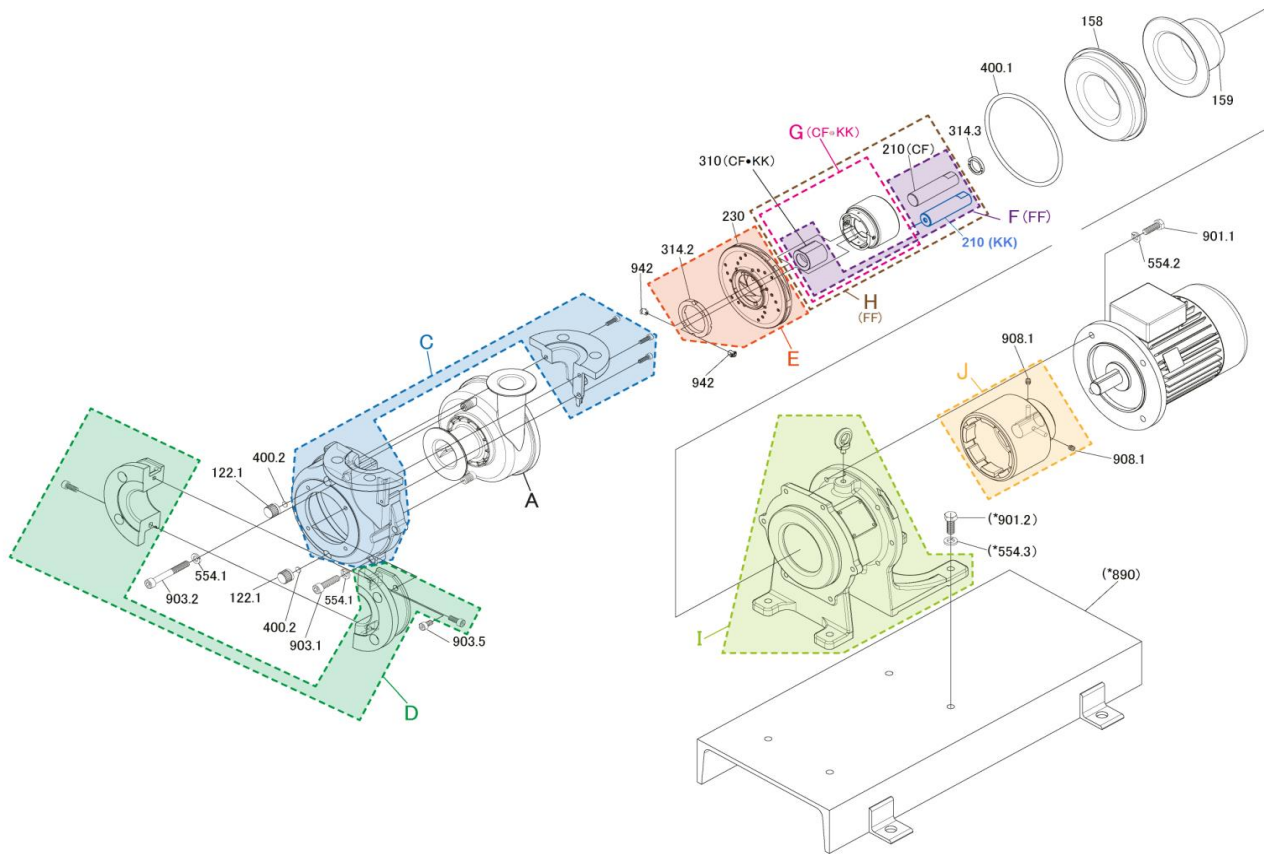

Rép	Description	Qté	Type	Matériau	Réf	Code No.	
A	Corps avant + butée	1	CF•FF	CFRETFE+Ceramic	MXM0076	1210040910	
		1	KK	CFRETFE+SiC	MXM0077	1210040920	
C	Renfort A / B	40mm	1	ISO	Ductile Iron	MXM0098	1220301220
		1,5"	1	ANSI	Ductile Iron	MXM0103	1220301230
		40mm	1	JIS	Ductile Iron	MXM0115	1220301210
D	Renfort 'C'	50mm	1	ISO	Ductile Iron	MXM0099	1220301420
		2"	1	ANSI	Ductile Iron	MXM0104	1220301430
		50mm	1	JIS	Ductile Iron	MXM0116	1220301410
122.1	Bouchon de purge (M14x2)	2		ETFE	MXM0114	1240644600	
158	Corps arrière	1	H	CFRETFE	MXM0080	1220299900	
159	Renfort de corps arriere	1	H	FRP	MXM0081	1231142400	
210	Axe	1	CF	Alumina Ceramic	MXM0151	1240830000	
		1	KK	SiC	MXM0002	1240886500	
230	Turbine <1> [1XF]	Ø 150 mm	1	1501	CFRETFE	MXM0048	1231149810
		Ø 140 mm	1	1401	CFRETFE	MXM0049	1231149820
		Ø 120 mm	1	1201	CFRETFE	MXM0050	1231149840
	Turbine <3> [3XF]	Ø 154 mm	1	1503	CFRETFE	MXM0062	1231150400
		Ø 140 mm	1	1403	CFRETFE	MXM0052	1231150010
		Ø 130 mm	1	1303	CFRETFE	MXM0053	1231150020
	Turbine <4> [4XF]	Ø 110 mm	1	1103	CFRETFE	MXM0159	1231150040
		Ø 154 mm	1	1504	CFRETFE	MXM0055	1231150110
		Ø 140 mm	1	1404	CFRETFE	MXM0056	1231150120
		Ø 125mm	1	1254	CFRETFE	MXM0058	1231150140
310	Palier	Ø 110mm	1	1104	CFRETFE	MXM0060	1231150160
			1	CF	High Density Carbon	MX0487	1240765600
			1	KK	SiC	MX0488	1240765700
FF	Palier + Axe	1	FF	Alumina Ceramic	MXM0371	2270326920	
314.2	Bague avant	1	CF•FF	PTFE	MX0303	1240736000	
		1	KK	SiC	MDM0018	1240684600	
314.3	Butée arrière	1		CFRPFA	MX0457	1240965900	
*330	Entretoise	1,5•2,2kW	1	542•543	FCD450	MXM0069	1220300720
		4,0kW	1	545	FCD450	MXM0094	1220300820

MXM 542•543•545

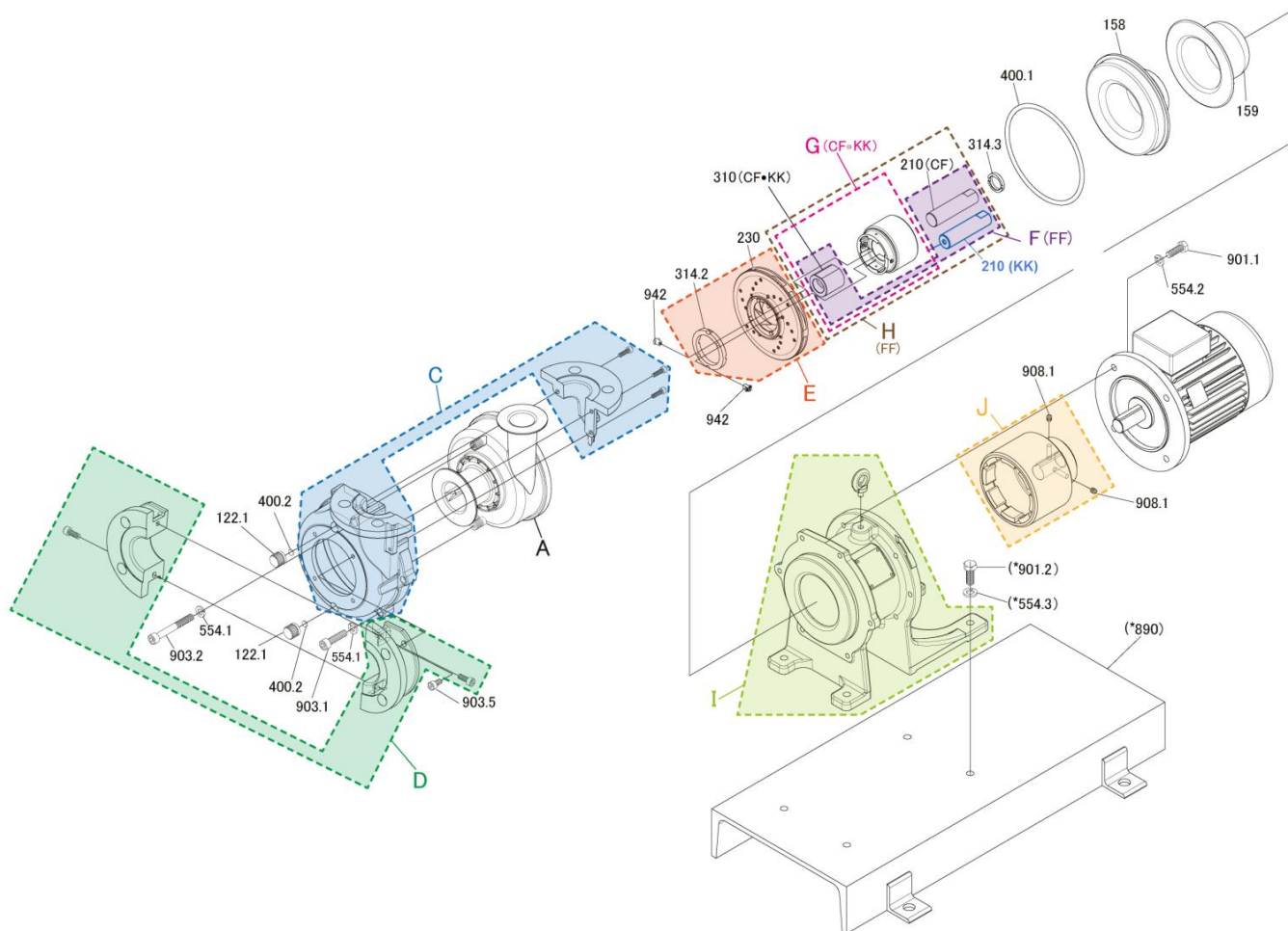

Rép	Description	Qté	Type	Matériau	Réf	Code No.	
400.1	Joint torique <G-165>	1	V	FKM-A	MX0116	0325300068	
		1	E	EPDM	MX0207	0325300080	
		1	A	Aflas®	MX0772	0325300108	
		1	P	DAI-EL Perfluoro®	MXM0014	0325300280	
400.2	Joint (t: 2mm, Ø 12mm)	2	V	FKM-A	MXM0009	1240010300	
		2	E	EPDM	MXM0010	1240014200	
		2	A	Aflas®	MXM0011	1240102200	
		2	P	DAI-EL Perfluoro®	MXM0015	1240465900	
J	Entraîneur (avec 2 x 908.1)	1,5kW [DJ2H]	1	542	MXM0067	1220300000	
		2,2kW [DJ3H]	1	543	MXM0088	1220300100	
		4,0kW [DJ5]	1	545	MXM0092	1220300200	
G	Capsule mag. + Palier	1,5•2,2kW	1	542•543-CF	CFRETFE+Carbon	MX0453	1231266210
			1	542•543-KK	CFRETFE+SiC	MXM0005	1231266250
		4,0kW	1	545-CF	CFRETFE+Carbon	MX0462	1231266310
			1	545-KK	CFRETFE+SiC	MXM0013	1231266350
H	Capsule mag. + Palier + Axe	1,5•2,2kW	1	542•543-FF	CFRETFE+Ceramic	MXM0368	2270326830
		4,0kW	1	545-FF	CFRETFE+Ceramic	MXM0369	2270326840
942	Pion	2		CFRETFE	MX0489	1240765900	
554.1	Rondelle grower (Renfort 'A/B') M10	6		SUS304 equivalent	MDM0030	0154100022	
554.2	Rondelle (Moteur) M10	4	542•543	SUS304 equivalent	MDM0030	0154100022	
	Rondelle (Moteur) M12	4	545	SUS304 equivalent	MDM0029	0154100024	
900	Anneau de levage M10	1		Steel	MDM0041	0150100181	
901.1	Vis (Moteur) M10x30	4	542•543	SUS304 equivalent	MDM0136	0150100207	
	Vis (Moteur) M12x35	4	545	SUS304 equivalent	MXM0071	0150300045	
903.1	vis (Renfort 'A/B') M10x40	5		SUS304 equivalent	MXM0070	0150300567	
903.2	Vis (renfort 'A/B') M10x80	1		SUS304 equivalent	MXM0075	0150300030	
908.1	Vis BTR (Entraîneur) M8x10	2		Steel	MDM0044	0152100046	

MXM 542•543•545

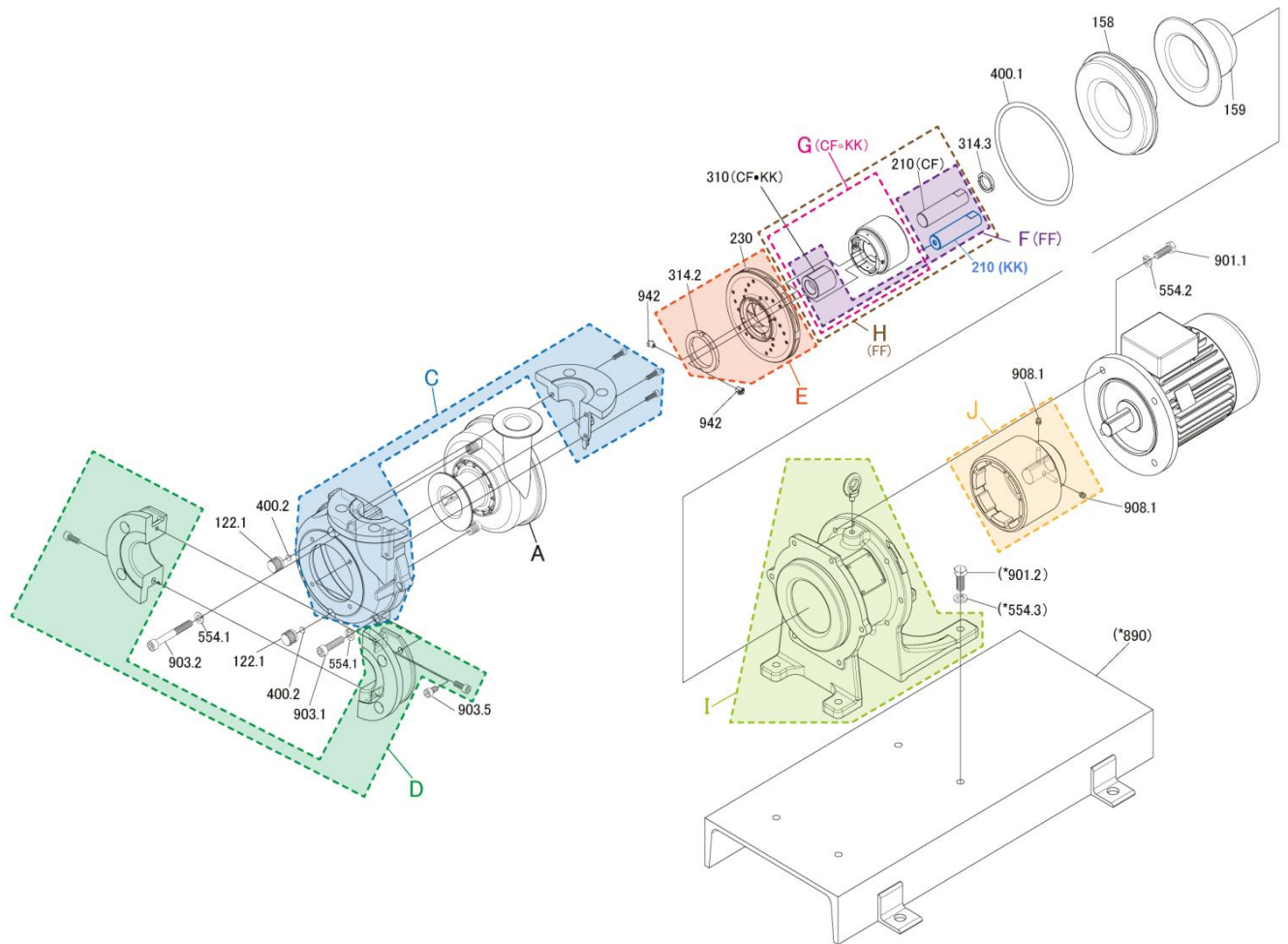

Rép	Description	Qté	Type	Matériau	Réf	Code No.	
E	Turbine <1> + Bague [1XF]	Ø 150 mm	1	1501-CF•FF	CFRETFE+PTFE	MXM0018	1231149010
		Ø 140 mm	1	1401-CF•FF	CFRETFE+PTFE	MXM0019	1231149020
		Ø 120 mm	1	1201-CF•FF	CFRETFE+PTFE	MXM0020	1231149040
		Ø 150 mm	1	1501-KK	CFRETFE+SiC	MXM0033	1231149410
		Ø 140 mm	1	1401-KK	CFRETFE+SiC	MXM0034	1231149420
		Ø 120 mm	1	1201-KK	CFRETFE+SiC	MXM0035	1231149440
	Turbine <3> + Bague [3XF]	Ø 154mm	1	1503-CF•FF	CFRETFE+PTFE	MXM0023	1231149210
		Ø 140 mm	1	1403-CF•FF	CFRETFE+PTFE	MXM0024	1231149220
		Ø 130 mm	1	1303-CF•FF	CFRETFE+PTFE	MXM0025	1231149230
		Ø 110 mm	1	1103-CF•FF	CFRETFE+PTFE	MXM0157	1231149250
		Ø 154 mm	1	1503-KK	CFRETFE+SiC	MXM0038	1231149610
		Ø 140 mm	1	1403-KK	CFRETFE+SiC	MXM0039	1231149620
	Turbine <4> + Bague [4XF]	Ø 130 mm	1	1303-KK	CFRETFE+SiC	MXM0040	1231149630
		Ø 110 mm	1	1103-KK	CFRETFE+SiC	MXM0158	1231149650
		Ø 154 mm	1	1504-CF•FF	CFRETFE+PTFE	MXM0027	1231149310
		Ø 140 mm	1	1404-CF•FF	CFRETFE+PTFE	MXM0028	1231149320
		Ø 125mm	1	1254-CF•FF	CFRETFE+PTFE	MXM0030	1231149340
		Ø 110mm	1	1104-CF•FF	CFRETFE+PTFE	MXM0032	1231149360
		Ø 154 mm	1	1504-KK	CFRETFE+SiC	MXM0042	1231149710
		Ø 140 mm	1	1404-KK	CFRETFE+SiC	MXM0043	1231149720
	Ø 125mm	1	1254-KK	CFRETFE+SiC	MXM0045	1231149740	
Ø 110mm	1	1104-KK	CFRETFE+SiC	MXM0047	1231149760		
*890	Base	1	"B"	Steel	MXM0085	1231158600	
*554.3	Rondelle Grower (Base) M12	4	"B"	SUS304 equivalent	MDM0029	0154100024	
*901.2	Vis (Base) M12x30	4	"B"	SUS304 equivalent	MDM0042	0150100206	